

Featherlite[®]

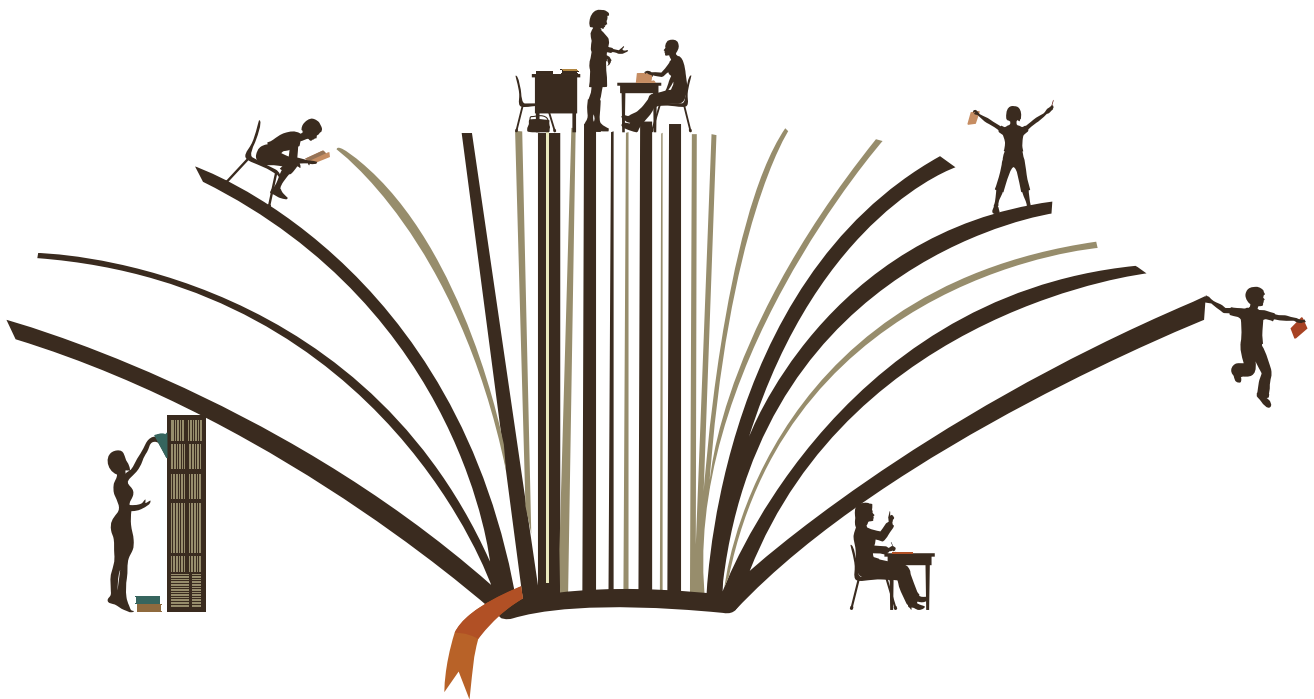

Supporting Education

A Range of Academic Furniture from Featherlite

50
YEARS
Work Better
Live Better

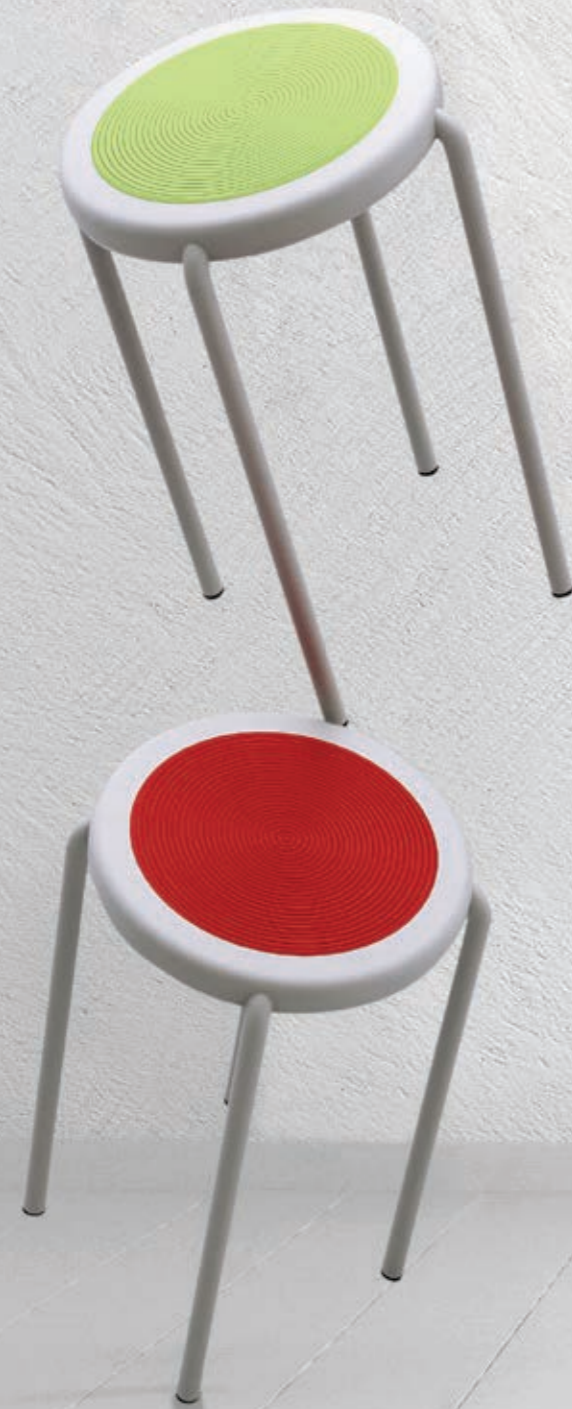

Education is the seed to success. Learning and imparting knowledge gets innovative by the day with the infrastructure and the learning space keeping pace with such ever changing times.

We design and engineer furniture for the academic space that enables contemporary learning while perfectly equipping the gurus and the disciples.

Our top notch academic furnishing solutions encompass every infrastructure setup possibly imaginable.

Balancing Comfort & Functionality

Classroom Furniture



Library Furniture



Seminar Desk



Hostel Furniture



Computer Labs



Classroom Chairs



Cafeteria



Lab Furniture



Cabin Furniture



Admin Chairs



Public Seating



Metal Storages



Reception Lounge





Pes

PES is designed keeping in mind our sharp young generation with an excellent learning curve. PES comes in a square tube model that defines the sharp intellect. Joined to form a single unit, it is compact with a sheet metal shelf and a sturdy finish.

Round Tube Bench



Square Tube Bench

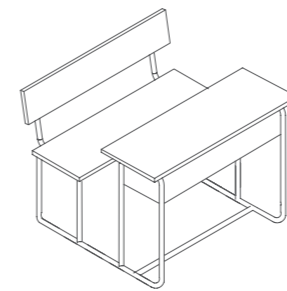

2 Seater
L : 1200mm
D : 900mm
H : 720mm

3 Seater
L : 1800mm
D : 900mm
H : 720mm

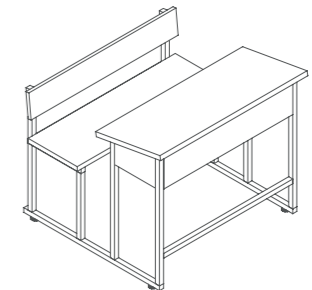

2 Seater
L : 1200mm
D : 900mm
H : 720mm

3 Seater
L : 1800mm
D : 900mm
H : 720mm

Oxford

A classic design with a modern ergonomic twist makes Oxford perfect for comfort seating as the desk and the bench are standalone units, including storage space, cosy angular backrest, a unique clamp for hanging bags in the desk and a wider seating base in the bench for comfort.

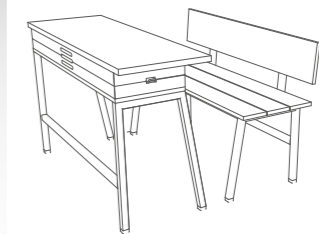

2 Seater (Desk)
L : 1200mm
D : 450mm
H : 750mm

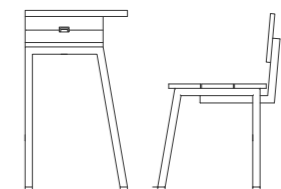

2 Seater (Bench)
W : 450mm
H : 750mm

Classroom Furniture

Our versatile Classroom Furniture Range offer creativity & comfort. Perfect designs allow comfortable movement and encourage the right sitting posture. A compact design yet comfortable space ensures that this range is suitable for every classroom space and creates an exciting new perspective to learning.

Firmo

Sturdy, compact, spacious and a unique design element encompass the features of Firmo. The front structure is a desk with a modesty panel, the middle structure is a desk and a bench and the last structure is just the bench. These three structures attached into one, without compromising on movement within the structures and dimensions can be customised in case of large requirement which makes Firmo an ideal choice.

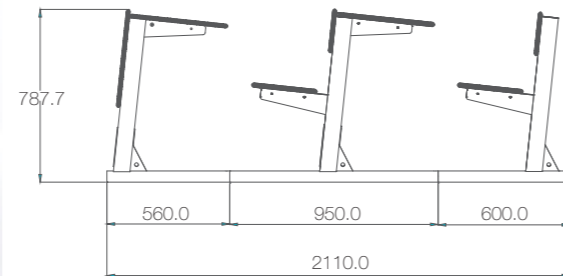

Edge

Edge is designed with simplicity, yet a sturdy structure for extreme comfort and a mesh book shelf. The two chairs adopt a similar mesh design, and electing this indeed gives the perfect scholastic edge.

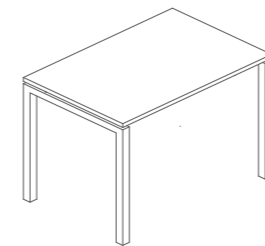

L : 1200mm
D : 450/600mm
H : 750mm

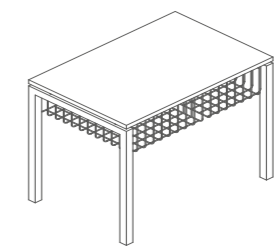

L : 1200mm
D : 450/600mm
H : 750mm

Viva

A lightweight, small yet comfortable design of the Viva combined with an angular design and base grips for a scratch free flooring enables easy movement. The chair and desk being separate units, makes stacking easy. Viva is available in a uni-seater or twin-seater combo.



J Leg

A solid wooden top, metal base legs and a modesty panel joining the legs, forms the basic shape of J Leg, which is a good choice for simple and modern study spaces.

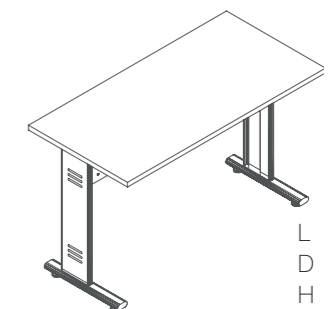
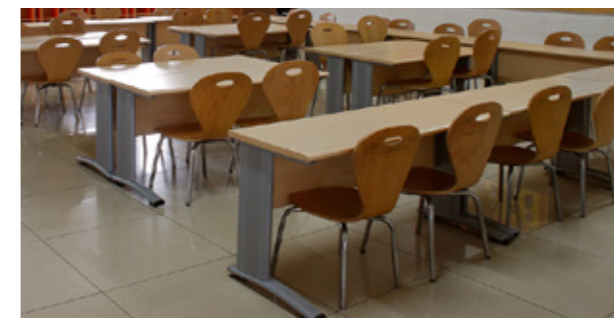

L : 900/1200mm
D : 450/600mm
H : 750mm



Library Furniture

Customising your encyclopaedic arrangements and zero disturbance study spots at a library setup just gets easier with Featherlite's Library Range. An A'Design Award 2014 winner for one of our front runners in the Library Design segment only reflects our international acclaim. Choose from our simple range of display racks and Carrel Desks to complete your Library collection.

Guide



One Sided Library Rack

Introducing the star of the Library Range, "Guide". Designed to perfection and the winner of the International A'Design 2014 Bronze Award in Milan (Furniture, Decorative items & Homeware Design Category), it can be colour coded and indexed, enabling anyone to find the knowledge they desire among the vast ocean of books. With a modern 'Metro' curve at one end, 'Guide' can be extended infinitely with extra racks at the other end to make a one sided library rack or even attached parallel to another rack and make it a two-sided rack, that can again be extended infinitely.



Back To Back Library Rack

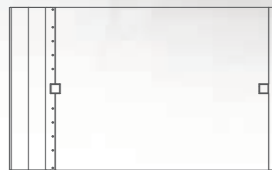

L : 1130/900mm*
D : 700mm
H : 1975mm



One Sided Library Rack



L : 1130/900mm
D : 350mm
H : 1975mm

* Length of first unit = 1130mm, Length of addon unit = 900mm

Display Rack

Journal Racks & Magazine Racks comprise our display rack range that are simplistic, yet tasteful and are built to do the job. Journal racks have door style glass casings that offer good protection and the Magazine Racks have the perfect in-slant storage design to keep magazines & tabloids.



Journal Rack

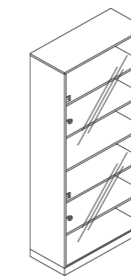

L : 900mm
D : 400mm
H : 2100mm



Magazine Rack

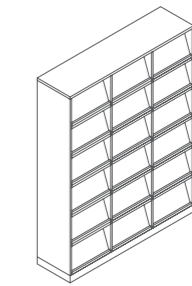

L : 1500mm
D : 400mm
H : 2100mm

Carells/ Tables

Students who demand zero disturbance for utmost concentration in a Library, will love our Study Tables & Carells that are designed with optimal customisability, where partitions can be placed for privacy.

Study Tables

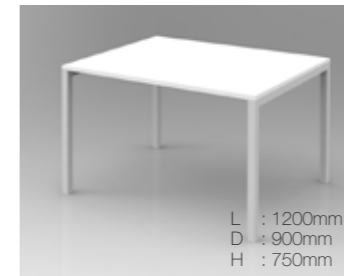

L : 1200mm
D : 900mm
H : 750mm

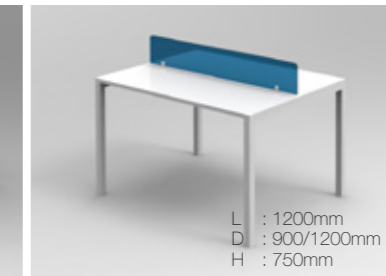

L : 1200mm
D : 900/1200mm
H : 750mm

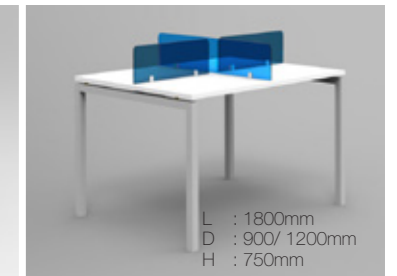

L : 1800mm
D : 900/ 1200mm
H : 750mm

Study Carells

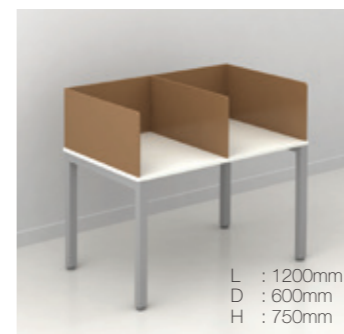

L : 1200mm
D : 600mm
H : 750mm

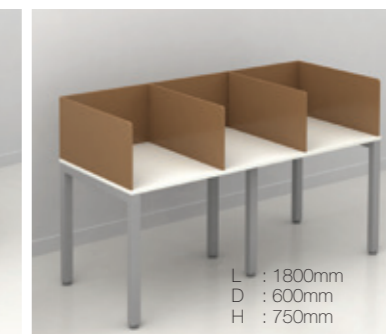

L : 1800mm
D : 600mm
H : 750mm

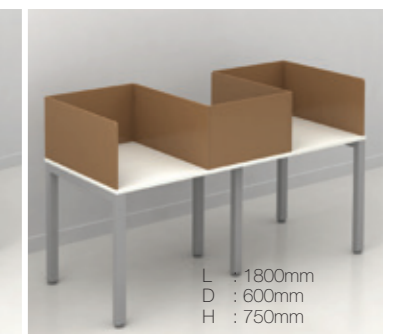

L : 1800mm
D : 600mm
H : 750mm

Grow

With a frontal pattern that signifies connectivity, Grow is uniquely designed with the option of attaching a filler plate in between two desks that help in creating an angle of up to 18°. Attach more desks with such filler plates and you have the perfect setup for a seminar hall no matter what the structure's radius is. It also allows you to manage data and electrical requirement to any seat.

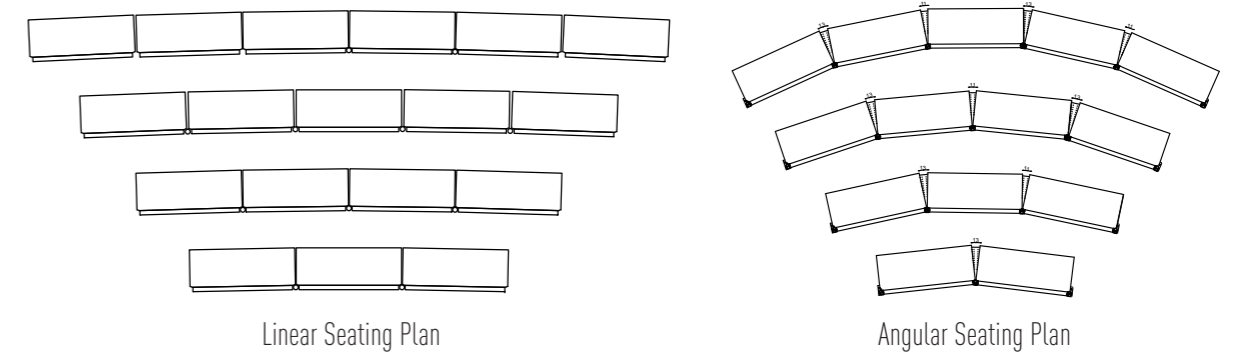
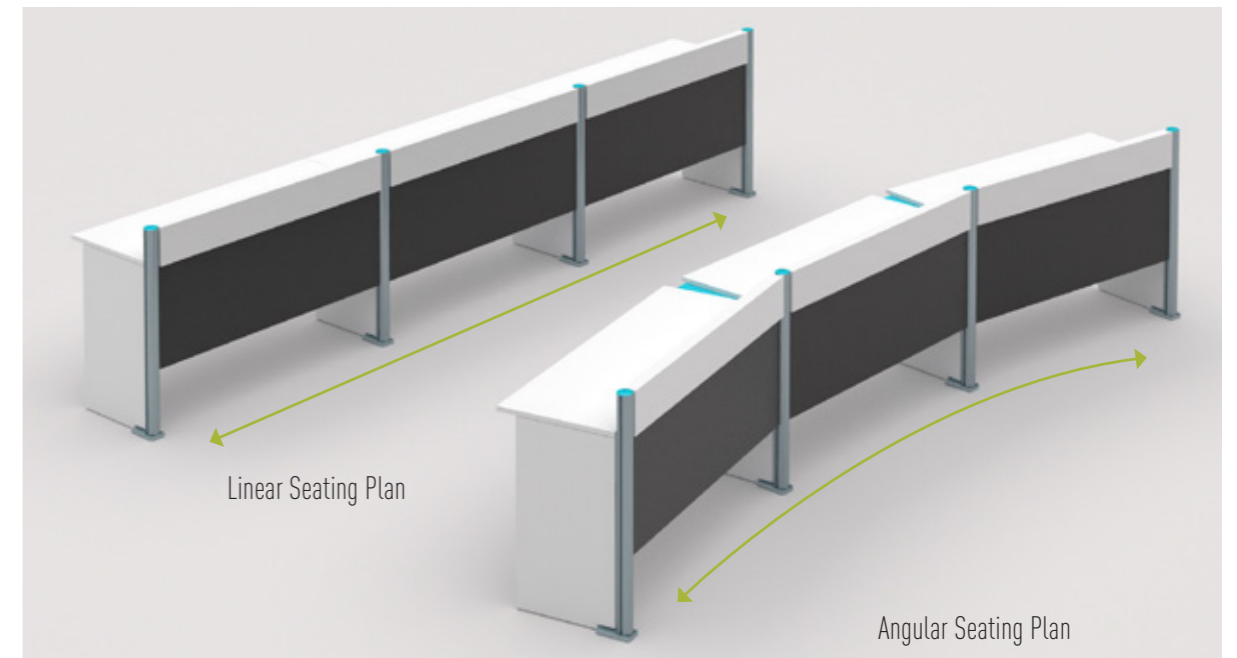

Seminar Desk

Seminars can now go on with style, comfort & success, where our Seminar Desks are installed. Invented as permanent fixtures, specifically to fulfil the needs of a seminar hall, these desks play a pivotal role during all Seminar arrangements.



Q-Boid

Created to perfectly sync with cuboid spaces, the Q-BOID series comes in three variants, 'Independent', 'Bunk Bed' & 'All In One'. A table, a bed and a storage closet are intellectually designed into these three series and every option equally prioritises space and privacy.

Independent Series

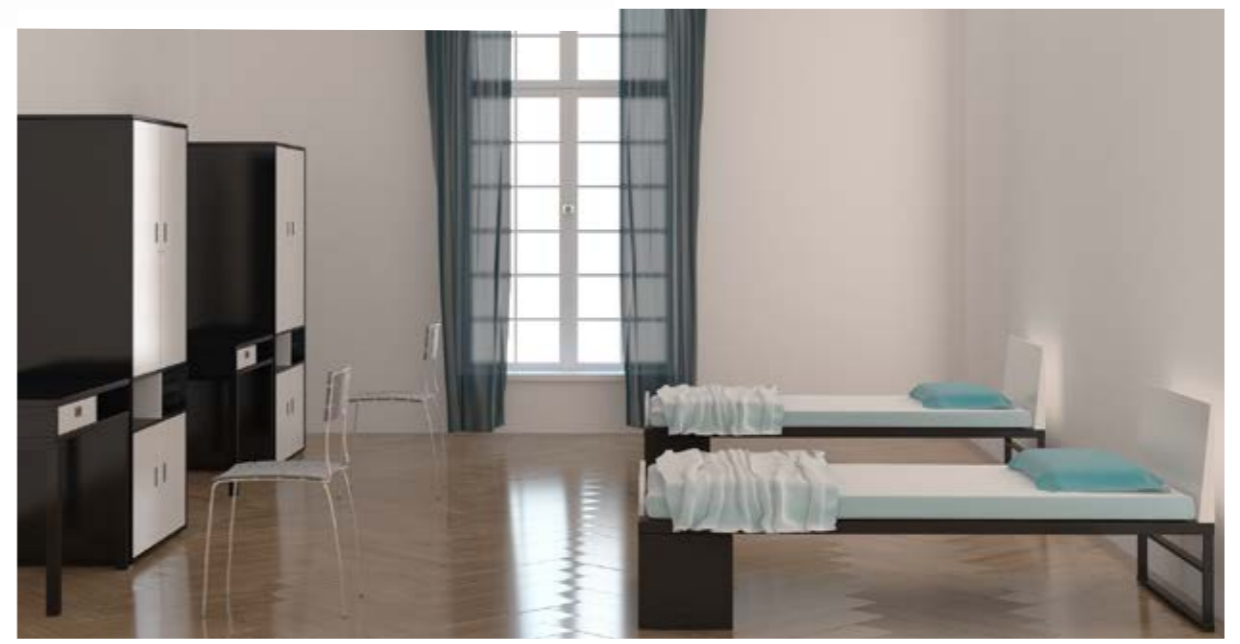

Hostel Furniture

We believe in creating aesthetic space to accentuate the feeling of home while designing hostel furniture. It is important that the ambience we provide must inspire harmony among the roomies. Various combinations, can be adapted to different situations and breed constructive interactions among the boarders.

All In One Series



Edge Study Table

Available in a combination of various wall storage units and a pin-up board, the Edge Study Table that helps in utmost concentration. It is made up of a tubular metal structure and a PLB (Pre Lam Board) table top fulfilling a fully functional simple design structure.

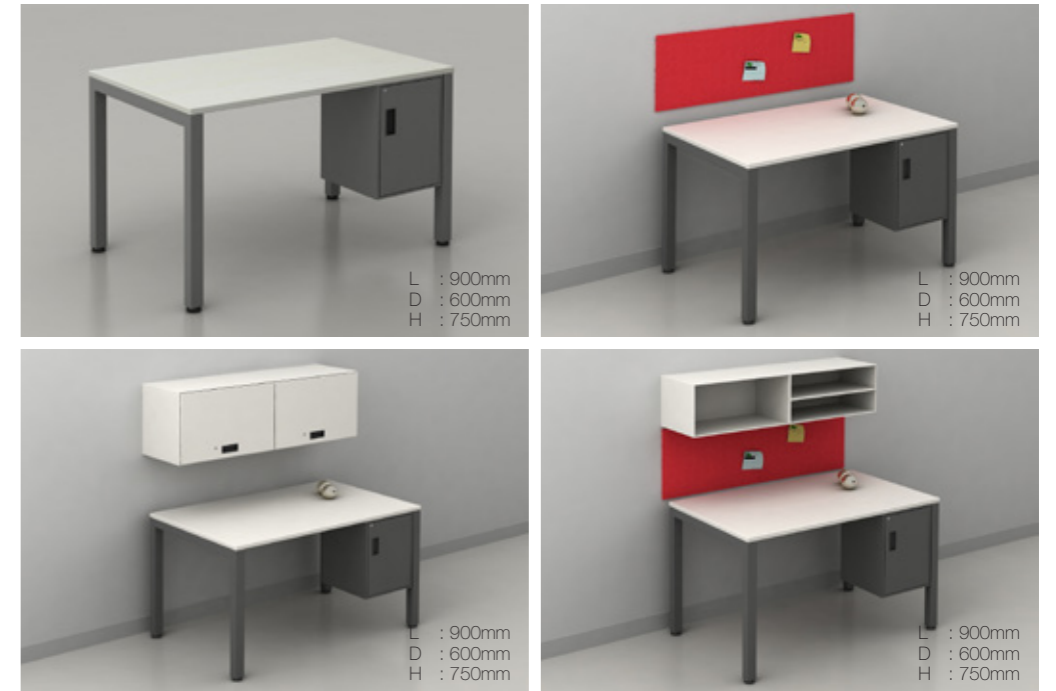

Bunk Bed Series



Reside

An elite combo of a cot with storage space, a study table with storage space, wall units & pin-up board and a storage cabinet completes 'Reside'. An excellent finish gives these set of products an elegant look and elevates the room's ambience.





Neo

Subtle magnetic board colours integrated with a premium white shade, Flexi Plan personifies a professional working environment and motivates students to a more mature and competitive behaviour.



L : 1800mm
W : 600mm
H : 900mm

Edge

Designed intuitively for a multi-functional computer lab setup, Edge acts as a flexible option for an individual or a team work environment with the option of partitions. Also available is the single system table with one wire manager for core production based training where more than one display monitors have to be used.

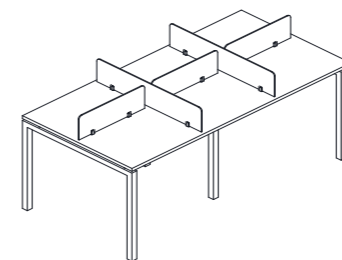

L : 1800mm
W : 1200mm
H : 900mm

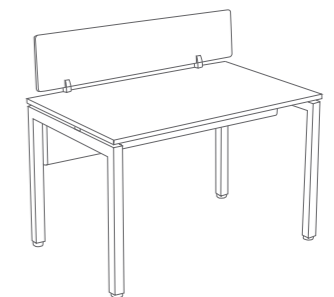

L : 900mm
W : 600mm
H : 900mm

Computer Labs

Students can now do wonders in a computer with our space friendly range of customisable computer lab furniture. Coding, designing, interactive learning or anything else practically taught to students, gets to be more enjoyable with no interference or complaints of space constraints and a tangle free setup, when computer labs are equipped with our uni-top computer table designs.



Class Room Chairs

Classroom Chairs are offered in an extensive range, mixing materials and shades rightly to create comfort, style and relaxation, inspiring students to perform better. Most of our range come with the option of an arm rest and a writing pad and can fulfil all classroom furnishing needs.

Forum



Forum Series

Perfo



Perfo Series

Magna



Magna Series

Addon



Addon Series

Seminar



Bodyline Va Wd



Contact 5 Wd



Perfo 5 Wdm



Addon 5 Wd



Raddon Wd



Forum Wd



Cafeteria

A quick bite or a long break, our Cafeteria range complement the hangout needs of all at the academy. Sit down for a long round of chatting, an unofficial meeting, discussing work, or even an academic event planning while lunching with your peers, our canteen chairs and tables do the perfect job. What's more, there is no fuss, cleaning the mess, thanks to the stain free materials this range is made of. So munch away your appetite.

Cafe Tables

Available in three basic geometrics, the café tables serve as the ideal round table gossip spot with a sip & a bite to make the conversation interesting.



∅ Round
800mm
Available colors : ■□



□ Square
800mm
Available colors : ■□



□ Rectangle
1200x800mm
Available colors : ■□

Cafe Chairs

Café Chairs with their vibrant colours and varied designs elevate comfort and appeal. These lightweight chairs are easily stackable, conserving or creating space.



Ally Stool



Roset



Fog Dc 7A ■ □ ■



Fresco ■ □ ■ ■ ■ ■



Rage Dc 30



Mint Choc Chip M C - 1



Ice ■ □ ■



Iq ■ ■ ■



Flex - 4 ■ ■ ■ ■ ■ ■



Tulip Dc 32



Lab Tables



A minimalistic product with granite table top and post laminated marine plywood parts, it also offers a stand for keeping chemicals.



This lab table can be useful for both Physics and Chemistry labs which comes with sink. It is made up of granite table top and post laminated marine plywood parts.



An ideal electronic lab table with tubular frame structure and laminated wooden top.

Lab Furniture

Featherlite has a wide spectrum of lab furniture, customised for each variant necessity & produced at an ultramodern manufacturing facility with state-of-the-art machinery. The chemistry lab tables are made chemical & water resistant. The physics lab tables come equipped with storage units. The Electronic lab tables created for the engineering geniuses have MS raceways installed for proper wire management and an obstruction free, practical environment!

*All these lab tables can be customised as per requirement



Cabin Furniture

Executive Desks embody power and perfectly fit the cabin space of those in authority. Aesthetics & Performance are synthesised into this exclusive range to ensure every managerial environment is optimised for productivity and organised functioning.

Zen

Zen, designed for the crème of the authority, gives an elegant feel and look that they deserve. It provides comfortable leg room and easy access to important documents storable in the pedestal that comes attached with this unit. Also available are additional storage units in the same contemporary & refined theme as Zen.

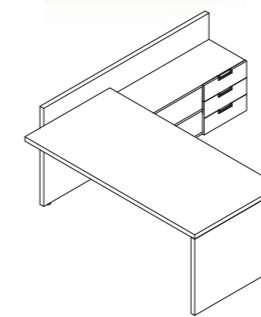

Main Table
H : 720mm
W : 1800mm
D : 900mm
+modesty panel

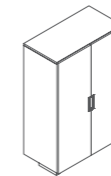

Storage 1
H : 1200mm
W : 750mm
D : 400mm

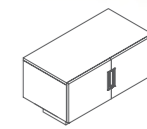

Storage 3
H : 400mm
W : 750mm
D : 400mm



Pedestal
H : 450mm
W : 450mm
D : 400mm
on casters

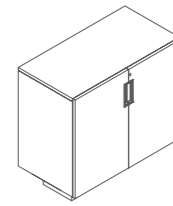

Storage 2
H : 700mm
W : 750mm
D : 400mm

Gamma

A classy wooden finish makes Gamma a fabulous choice for the top management's workspace. With the options of extra storage units that sync perfectly with the cabin table, there is enough space to store work files or proudly display mementos and awards achieved for excellence.

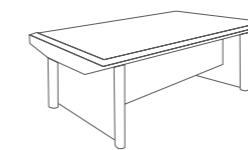

Standard Desk
Code no. ZM-GDDK 180
L1800mmXB900mmX760mm
Code no. ZM-GDDK 220
L2000mmXB1000mmX760mm
Code no. ZM-GDDK 180
L2000mmXB1000mmX760mm



Mobile Pedestal
Code no. ZM-GDMP 3D
L420mmXB510mmX560mm

Half Glass Cabinet (W/O Frame)
Code no. ZM-GDHG 200C
L900mmXB460mmX1980mm

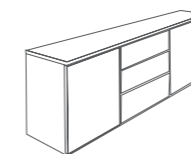

Credenza
Code no. ZM-GDDZ184
L1810mmXB460mmX740mm

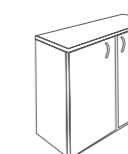

2 Door Side Return
Code no. ZM-GDSR 2D
L1000mmXB450mmX680mm

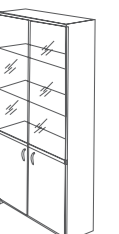

Flite

Flite adds comfort to your work atmosphere with a clean and simple laminated finish. Cabinets are available in varied sizes and are designed perfectly for the management cadre, offering easily accessible storage.

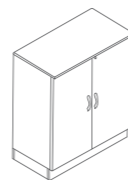
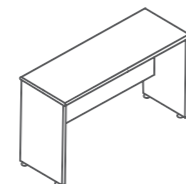
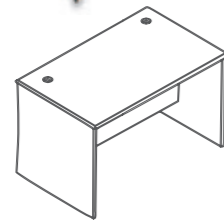

Writing Table

Code no. FL- 1890(B)
L 1800mm x B 900mm x H 750mm
Code no. FL- 1675(B)
L 1600mm x B 750mm x H 750mm
Code no. FL- 1275(B)
L 1200mm x B 750mm x H 750mm

Hanging Pedestal (3 Drawer)

Code no. FL- H3(B)
L 400mm x B 500mm x
H 480mm

Free Side Return

Code no. FL- 1245(B)
L 1200mm x B 450mm x
H 700mm

Swinging Door Cabinet

Code no. FLW- 808(B)
L 797mm x B 410mm x
H 915mm

Versaline

Versatility symbolises this range of office furniture, purely due the exhaustive range available in the worktable and storage options. Varying sizes and combinations, yet affordability and quality finish, makes Versaline one of the most preferred series as against its market competition.

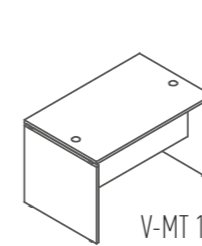

V-MT 1275
1200L x 750D x 750 HT

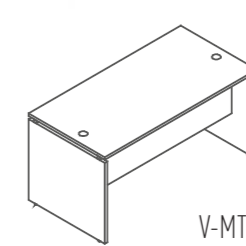

V-MT 1575
1500L x 750D x 750 HT

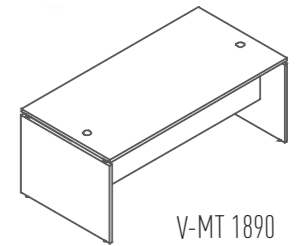

V-MT 1890
1800L x 900D x 750 HT

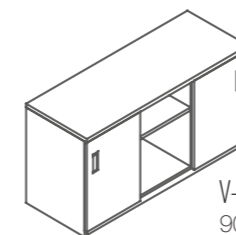

V-ST 9045(LH & RH)
900L x 450D x 750 HT

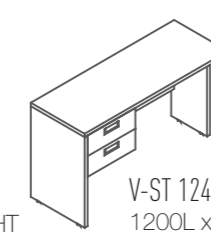

V-ST 1245(LH & RH)
1200L x 450D x 750 HT

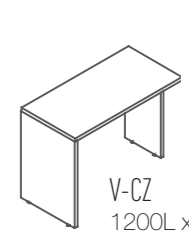

V-CZ
1200L x 450D x 750 HT



Admin Chair

Featherlite's series of admin chairs are renowned and the best in India, thanks to the comfortable, sturdy yet aesthetic designs. A wide & luxurious choice of admin chairs cover all types and needs for a seating arrangement.

Optima

An optimal choice for the admin space, the Optima range is available in a range of colours, materials & designs that provide customised elevation and reclining to ease the work atmosphere.



Invention

A uniform seating design is followed in the Contact range with variations in the backrest and movement. This caters to varying levels at the workspace.



Contact

A uniform seating design is followed in the Contact range with variations in the backrest and movement. This caters to varying levels at the workspace.



Ergon

The svelte & sturdy seating of the executive chair range is Ergon, which comes in varied options, with or without a headrest and extra leverage for the backrest providing ultimate support to the sitting posture.



Anatom

Anatom epitomises ultimate cosiness and strategic design for the right posture, sturdy back support and angular suspension to handle weight and repositioning. Available with or without a headrest, Anatom is the best seating option for long working hours.



Bravo

A wide cushion base and backrest is the key design of Bravo. A wheel movement or a sturdy base are the two options it is available in, but whichever option one chooses, it is sure to provide comfort and a breather for the teaching staff after long hours of lecture.



Smart



Student W-132



Multi



Student Flex-2



Auditorium Seating

Loaded with spring pivots in the seats that reverb to a vertical position in order to save space like in auditoriums, this range comes in three colourful and design variants: Click, Venus & Atlas. These solid permanent fixtures help planning the Auditorium setup better.



Click



Venus



Atlas

Tandem Seating

A lounge, a reception or any other public space where waiting is in order, these sturdy metal chairs on solid frames are built for high levels of endurance, wear & tear and long span of durability.



Brune Tandem 2ST M

Brune Tandem 2ST CU HR



Perfo Tandem 2ST M



Orbit Tandem 2ST CU



SJ820-3S



Contact Tandem 3ST

Public Seating

We give great emphasis on advanced design concepts to meet the wide ranging demands of public seating. We understand that space is a precious and finite resource. So, while designing your creative seating systems with style and durability we make sure to utilize the maximum advantage of space to provide you the perfect options for interior or exterior seating.



Metal Storage

Organising your files & documents gets easier with these metal storage units. Robust design and labelling options ensures easy access to the right document. Also available in the form of lockers with individual storage under lock and key built into one structure, these varied options provide proper storage and personal safekeeping.

Cupboards

Say goodbye to clutter, with these spacious & firm metal cupboards. Primarily useful as file cabinets at any admin workspace, they are available in two similar variants in different sizes and a drawer unit for organising unfiled papers.



C/CSD200(UL)-9
Cupboard swing doors with four shelves
5 level of box files, Capacity=50 box files
W 900 X D 450 X H 2015



C/CSD132(UL)-5
Cupboard swing doors with two shelves
3 level of box files, Capacity=30 box files
W 900 X D 450 X H 1340



FCV40(UL)
4 Drawer Unit
H :1320mm
W :458mm
H :622mm

Lockers

Personal storage units for students and management alike, lockers are sturdy constructions in 2 door, 4 door and 6 door cabinet options with individual locks to ensure utmost privacy.

Executive Filing Cabinets



C/G-LSS20-1+ C/G- LSA20-1
Locker Single Coloum
2 doors Starter Unit &
2 doors Add On unit
W 380 X D 457 X H 1830



C/G-LSS40-1+ C/G- LSA40-1
Locker Single Coloum
4 doors Starter Unit &
4 doors Add On unit
W 380X D 457 X H 1830



C/G-LSS60-1+ C/G- LSA60-1
Locker Single Coloum
6 doors Starter Unit &
6 doors Add On unit
W 380X D 457 X H 1830

Product Name: Qbe



Reception Lounge

The swank lounge furniture from Featherlite is designed to make waiting lounges look fabulous and cosy. Elegant colour & fabric options and design variations help elevate your décor and are suitable for break zones & casual meeting rooms as well apart from the lounge space.

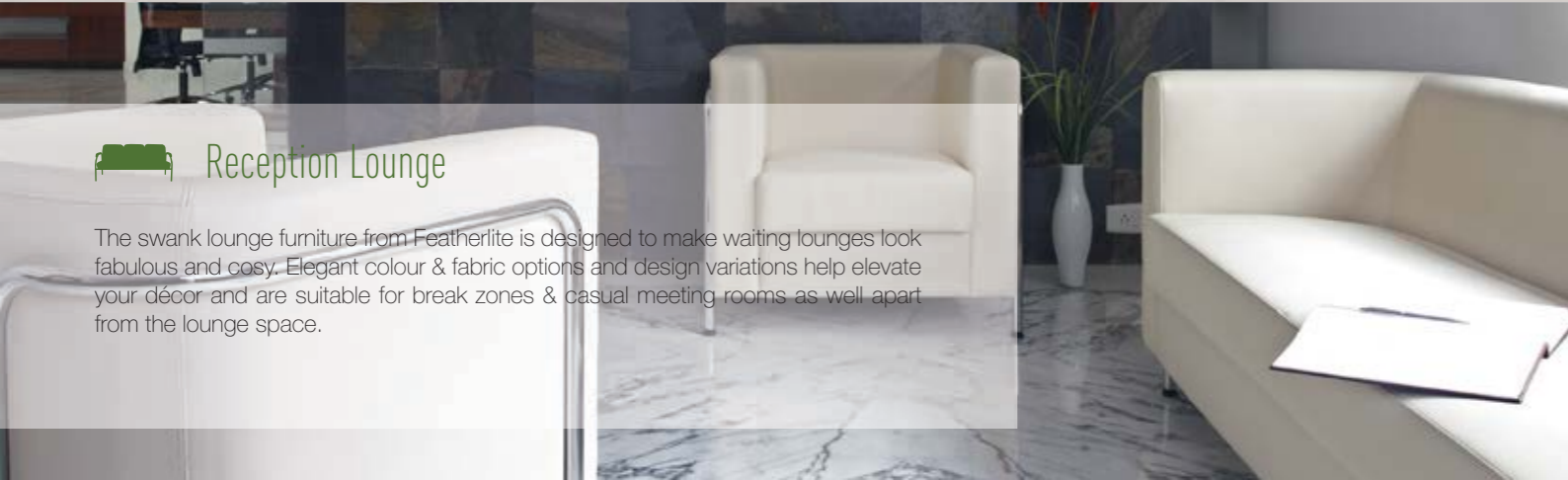

Pearl

Simply stunning in design, yet affordable, Pearl with a well-padded seating base and backrest, provides excellent comfort. Black & Ivory are the colours they are available in, representative of a classy appearance.



Model No. 238

1 Seater	3 Seater
L : 800mm	L : 1800mm
W : 725mm	W : 725mm
H : 700mm	H : 700mm

Available colors

- Black Leatherite
- Ivory Leatherite

Regency

A simple skeletal metal frame with non-removable cushions, Regency is a professional reception lounge, which comes in three colour variants with any fabric of your choice that complements the interiors of the waiting lounge, helping you project the image you wish to.



1 Seater	2 Seater	3 Seater
L : 650mm	L : 1220mm	L : 1740mm
W : 790mm	W : 790mm	W : 790mm
H : 750mm	H : 750mm	H : 750mm

Available colors

- Leatherite
- Any Fabric

FEATHERLITE OFFICE SYSTEMS (P) LTD.
 16/A, Millers Road, Vasanthnagar, Bangalore - 560 052
 Tel: 080-4020 9631 | e-mail: sales@featherliteindia.com
 www.featherliteindia.com

SHOWROOMS

Bangalore (Vasanth Nagar)	080-40209631	93424 55502
B'lore (Bannerghatta)	080-26481232	87626 89449
B'lore (Marathahalli)	080-42099068	96202 20217
B'lore (Whitefield)	080-65656686/87	
Ahmedabad	079-30071300	82380 32300
Ananthpur	08554-239020	94402 90233
Bhubaneshwar	0674-2354131	77357 30250
Chennai (Egmore)	044-28274752	98844 54784
Chennai (Haddows Road)	044-28232764	98844 01380
Chennai (Nandanam)	044-24327129	98422 20129/7
Coimbatore	0422-4357129	98422 20126/9
Davangere	08192-233564	99005 50099
Durgapur		98365 57900
Ernakulam	0484-2370440	94960 75508
Goa	0832-2781111	72760 34119
Guwahati	0361-2466235	94350 36547
Hubli	0836-4265288	95900 65288
Hyderabad (Somajiguda)	040-23374045	77999 25009
Hyderabad (Gachibowli)	040-40066272	98855 07050
Indore	0731-4000566	74157 75000
Jaipur	0141-2604189	99501 45104
Jamshedpur	0657-2320370	94315 24051
Kochi	0484-2776935	93886 81284
Kolkata	033-23455065	93398 77051
Kolhapur	0231-2640917	93711 11878
Kurnool	08518-257333	94402 90233
Ludhiana		98766 71147
Lucknow	0522-4009973	99183 02012
Mangalore	0824-2425041	98801 88169
Madurai	0452-2629898	88708 22228
Mumbai (Malad)	022-67429192	80802 22339
Mysore	0821-4257220	97393 88080
Nagaland	03862-237112/08	96865 02941
Nagpur	0712-2446214	90280 17311
New Delhi	011-40638000	98109 14484
Noida	0120-4562364	95602 22011
Patna	0612-2270748	90310 22875
Pune	020-66012818	96650 55552
Rajkot	0281-2466055	93774 67219
Ranchi	0651-2532667	90310 22875
Raipur	0771-6054009	94255 03309
Salem	0427-4552323	98943 55232
Secunderabad	040-27802602	98666 33048
Shimoga	08182-279441	99005 50099
Surat	0261-2517300	97250 50010
Thiruvananthapuram		93886 81284
Tinsukia	0374-2331161	94350 36546
Tirupathi	0877-2281977	98661 48909
Vijayawada	0866-3042076	86864 66466
Vishakapatnam	0891-2530770	93463 30770

INTERNATIONAL SHOWROOM

Kathmandu, Nepal	977-16200209	98020 14440
------------------	--------------	-------------

